

Container discharger 360°

DGE

The rotating container discharger **DGE** rotates 360° and is developed for emptying containers and vessels. The load is picked up with the forks and supported at the sides by the clamping arms. To protect the containers, the attachment is equipped as standard with a pressure relief valve and pressure gauge. Fork positioning is manual. The Durwen direct drive rotator uses a worm wheel system protected against the ingress of dirt and will give a long service life. The unit is not designed for bale handling.

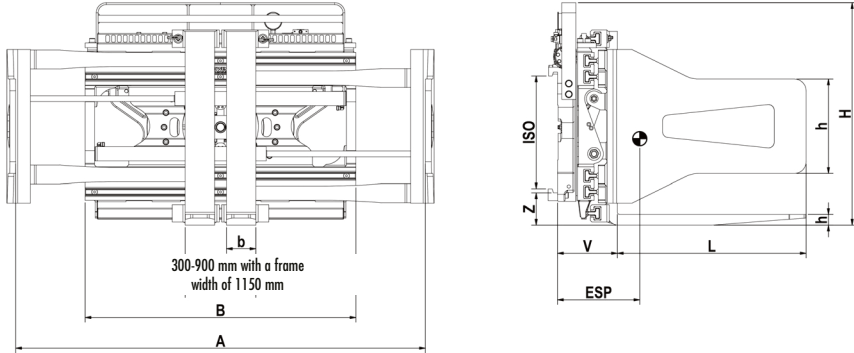

type	capacity kg/mm LC	lift truck to LC mm	ISO	B mm	opening range A ITI mm	forks b x h x L mm	arms L x h mm	Z mm	V LLC mm	ESP COG mm	weight kg
DGE 20	1500/500	1,0-2,0/500	II	1050 1150	480-1640 480-1740	100x40x800	800x400	136	246	219 217	740 755
DGE 25	2000/500	2,0-2,5/600	II	1050 1150	480-1640 480-1740	125x45x800			255	305 305	845 860
DGE 30	2500/500	3,0/500	III	1050 1150	480-1640 480-1740	125x45x800			255	315 305	850 865

- 2 hydraulic functions required (3 hydraulic functions with constant sideshift)
- includes hoses and couplings
- including pressure relief valve and pressure gauge
- safety valve as standard
- standard with protection strip type SB-DG (does not rotate)
- constant sideshift see page 240
- longer arms and forks upon request, max. length 1200 mm, data change, please ask
- rubber coated arms upon request

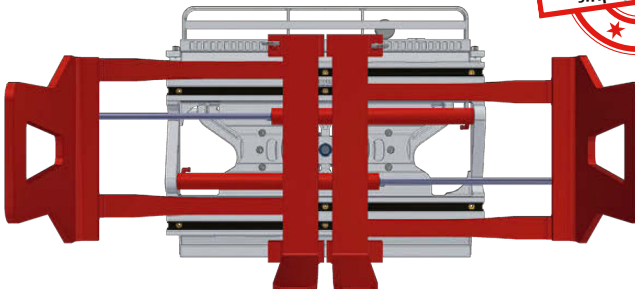

DURWEN
Forklift Attachments

More than 75 years experience