

# 360° rotator hydraulic claws

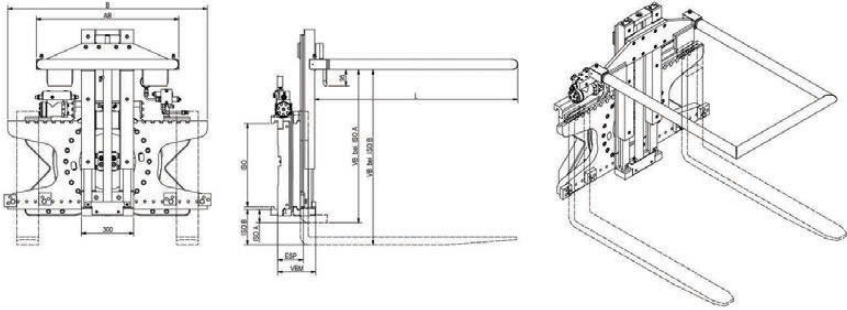

The rotator **DG-BK** has a bolt-on stabilizing arm and claws to fix a box (container) on the forks. This is a suitable solution whenever the box needs to be rotated 180° for emptying bulk material. The arm and the claws are hydraulically driven and secure the box onto the forks.



type	capacity kg/mm LC	lift truck capacity to	ISO	arm AB x L mm	B mm	max. torque ΔP 130 bar Nm	VB ISO A mm	VB ISO B mm	VBM LLC mm	ESP COG mm	weight kg
DG 20-BK	2000/500	2,0/500	II	820 x 1200	980	5200	650-1350	726-1426	206	145	415
DG 25-BK	2500/600	2,5/600	II	820 x 1200	1080	9400	650-1350	726-1426	209	135	430
DG 30-BK	3000/500	3,0/500	III	820 x 1200	1150	9400	650-1350	777-1477	219	136	480
DG 35-BK	3500/500	3,5/500	III	820 x 1200	1150	11700	650-1350	777-1477	224	141	495

- 2 hydraulic functions required
- includes hoses and couplings
- forks not included
- quick release hooks: (ISO II, III,) upon request
- solenoid valve upon request (12 V, 24 V, 48 V, 80 V - please specify)
- hook-on forks reinforced for rotator use must be used

type	capacity kg/mm LC	lift truck capacity to	ISO	arm AB x L mm	B mm	max. torque ΔP 130 bar Nm	VB ISO A mm	VB ISO B mm	sideshift mm	VBM LLC mm	ESP COG mm	weight kg
DG 20-S-BK	2000/500	2,0/500	II	820 x 1200	980	5200	650-1350	726-1426	+/- 100	256	180	462
DG 25-S-BK	2500/600	2,5/600	II	820 x 1200	1080	9400	650-1350	726-1426	+/- 100	238	160	475
DG 30-S-BK	3000/500	3,0/500	III	820 x 1200	1150	9400	650-1350	777-1477	+/- 100	264	165	545
DG 35-S-BK	3500/500	3,5/500	III	820 x 1200	1150	11700	650-1350	777-1477	+/- 100	269	170	560

- 3 hydraulic functions required
- includes hoses and couplings
- hook-on forks reinforced for rotator use must be used
- quick release hooks: (ISO II, III,) upon request
- solenoid valve upon request (12 V, 24 V, 48 V, 80 V - please specify)
- forks not included
- for special arm sizes, please ask

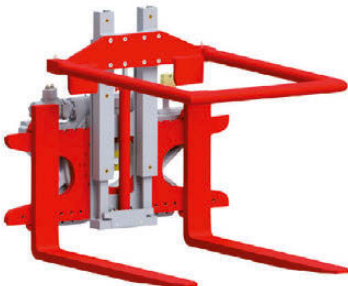

More than 75 years experience