

Appliance clamp, articulating arms

integral sideshift, with vertical and horizontal adjustable arms

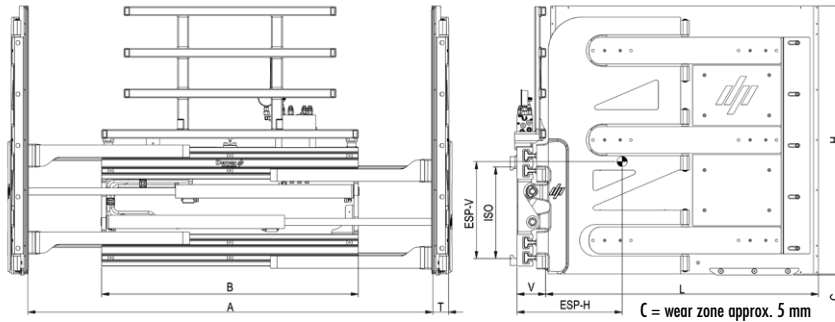

type	lift truck to LC mm	min. carriage mm	capacity kg LC mm	ISO	B mm	opening range A III mm	arm height H mm	arm length* L mm	arm thickness T mm	V LLC mm	COG/ESP hor. mm	COG/ESP vert. mm	weight kg	moving mass kg
KHG 11	1,5-1,8/500	795	1050/600	II	880	360-1400	1000	1220	60	129	425	358	675	534
		795			880	360-1400	1200	1220			450	426	715	586
		890			1050	430-1720	1000	1220			415	353	695	534
		890			1050	430-1720	1200	1220			445	422	735	586
		890			1050	430-1720	1200	1380			490	430	805	650
		900			1150	430-1820	1200	1220			440	420	755	586
		900			1150	430-1820	1200	1380			465	429	820	650
		1040			1250	430-1920	1200	1220			435	418	765	586
		1040			1250	430-1920	1200	1380			475	427	835	650
		1100			1550	560-2440	1200	1220			415	410	805	602
1100	1550	560-2440	1200	1380	445	420	875	650						
KHG 14	2,0-2,5/600	890	1350/600	II	1050	430-1720	1000	1220	60	129	415	351	700	534
		890			1050	430-1720	1200	1220			445	427	740	586
		890			1050	430-1720	1200	1380			490	429	810	650
		900			1150	430-1820	1200	1220			440	424	760	586
		900			1150	430-1820	1200	1380			465	426	825	650
		990			1350	430-2020	1200	1220			430	422	790	586
		990			1350	430-2020	1200	1380			455	423	850	650
		1100			1550	430-2220	1200	1220			425	420	805	602
		1100			1550	430-2220	1200	1380			445	422	875	650
		1100			1550	560-2420	1200	1220			425	418	810	615
1100	1550	560-2420	1200	1380	445	421	880	670						

- 2 hydraulic functions required
- includes hoses and couplings
- pressure gauge as standard
- with pressure relief valve on the clampfunction as standard
- with protection strip as standard
- RiGu black as standard surface

- other surfaces see page 252
- clamp force options see page 249
- other arm dimensions upon request
- constant sideshift upon request
- ISO type B mounting upon request

* arm length equals the usable length from the arm tip to the load contact on the clamp body, contact plate length - 20 mm

