

# Carton clamp, telescopic

constant sideshift, rigid arms

**KKS-T-S**

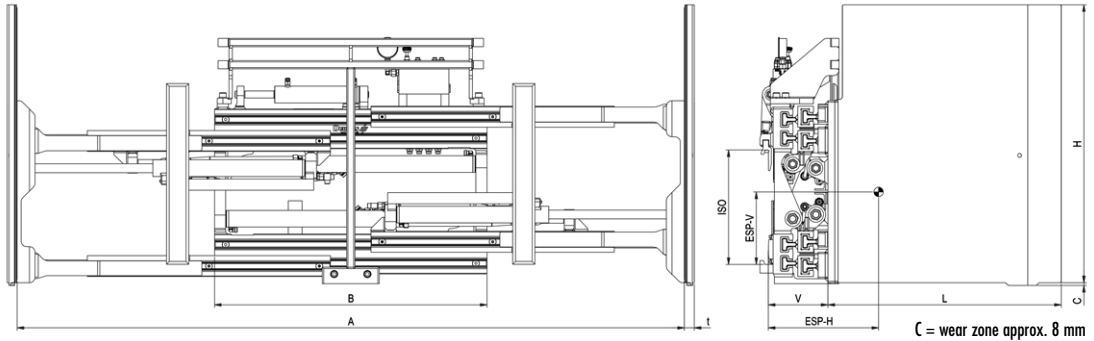

type	lift truck to LC mm	min. carriage mm	capacity kg LC mm	ISO	B mm	opening range A ITI mm	arm height H mm	arm length* L mm	arm thickness T mm	sideshift mm	V LLC mm	COG/ESP hor. mm	COG/ESP vert. mm	weight kg	moving mass kg
KKS 08 T-S	1,0-1,5/500	730	750/500	II	980	400-2400	1000	700	28	+/- 100	254	265	339	655	635
						400-2400	1000	800				305	342	690	671
						400-2400	1200	700				285	381	695	675
						400-2400	1200	800				325	390	740	721
						470-2480	1000	700				265	339	655	635
						470-2480	1000	800				305	342	690	671
						470-2480	1200	700				285	382	695	675
						470-2480	1200	800				325	390	740	721
KKS 11 T-S	1,0-1,5/500	730	1050/500	II	980	400-2400	1000	700	28	+/- 100	254	265	339	655	635
						400-2400	1000	800				305	342	690	671
						400-2400	1200	700				285	381	695	675
						400-2400	1200	800				325	390	740	721
						470-2480	1000	700				265	339	655	635
						470-2480	1000	800				305	342	690	671
						470-2480	1200	700				285	382	695	675
						470-2480	1200	800				325	390	740	721

- 2 hydraulic functions required
- includes hoses and couplings
- pressure gauge as standard
- constant sideshift as standard
- flow divider as standard

- with protection strip as standard
- RiGu black as standard surface
- other surfaces see page 252
- 3-stage pressure relief valve upon request
- other arm dimensions upon request

- clamp force options see page 249

\* arm length equals the usable length from the arm tip to the load contact on the clamp body

