

Tilting drum clamp with integral sideshift

PFK 90°/180°

The profile-guided tilting drum clamp type PFK features 90° (PFK 15-90°) or 180° (PFK 15_180°) rotation. The tilting drum clamp is able to empty steel drums and other containers to the front. The unit is equipped with integral sideshift. The arms are rubber-coated.

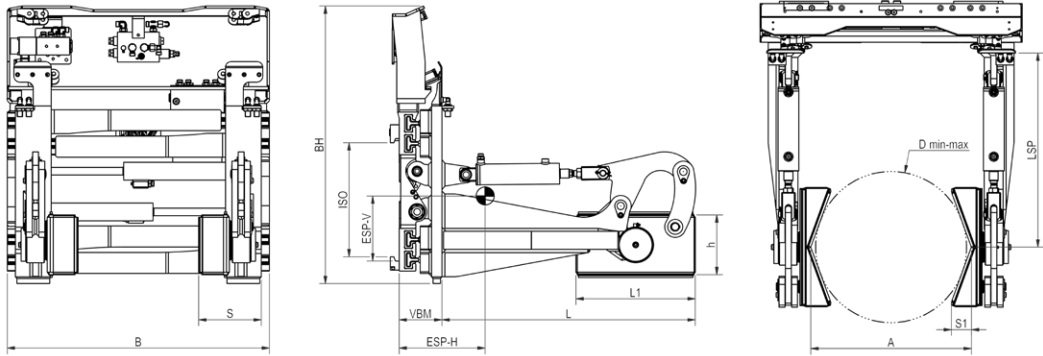

Tilting drum clamp 90°, with integral sideshift

type	lift truck to LC mm	min. carriage mm	capacity kg LC mm	ISO	B mm	for drum diameter A mm	height H mm	length L mm	S/S1 mm	V LLC mm	COG/ESP hor. mm	COG/ESP vert. mm	weight kg	moving mass kg
PFK 15-90°	1,5-2,0/500	720	300/650	II	880	260-800	200	400	210/67	144	288	218	443	317

Tilting drum clamp 180°, with integral sideshift

type	lift truck to LC mm	min. carriage mm	capacity kg LC mm	ISO	B mm	for drum diameter A mm	height H mm	length L mm	S/S1 mm	V LLC mm	COG/ESP hor. mm	COG/ESP vert. mm	weight kg	moving mass kg
PFK 15-180°	1,5-2,0/500	720	300/650	II	880	260-800	200	400	210/67	144	288	217	441	315

- 3 hydraulic functions required
- includes hoses and couplings
- with pressure relief valve on the clamp function as standard
- cylinder protection upon request
- constant sideshift +/- 100 mm upon request
- solenoid valve upon request (12 V, 24 V, 48 V, 80 V – please specify)

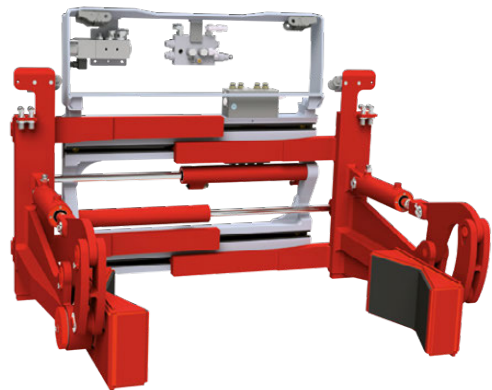
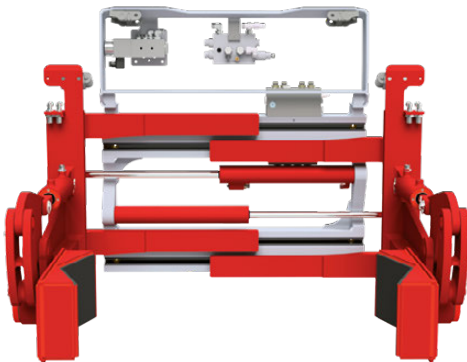

image shows option solenoid valve