

Paper roll clamp 360°

PRK 40
ISO III/IV

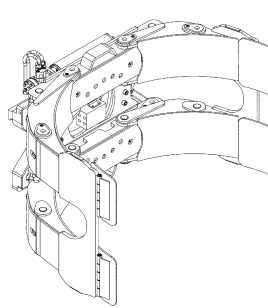

long arm unsplit

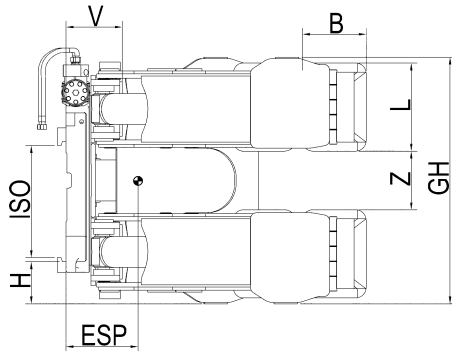
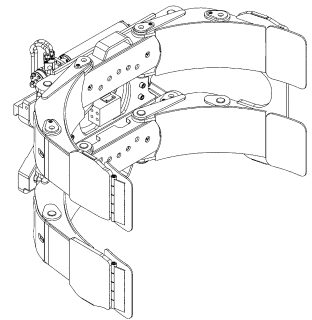

long arm split

type	capacity kg LC mm	min. carriage mm	ISO	roll diameter min - max mm	short arm	GH mm	contact plates B x L mm	Z mm	H mm	V LLC mm	COG/ESP hor. mm	COG/ESP vert. mm	weight kg
PRK 40 - Long arm unsplit													
PRK 40 B - 13	3000/650	1150	III/IV	250 - 1300	powered	1040	250x400	200	195/200	215	210	333	825
PRK 40 S - 13	3000/650			500 - 1300	fixed						210		820
PRK 40 B - 14	2800/725			250 - 1450	powered						225		860
PRK 40 S - 14	2800/725			500 - 1450	fixed						225		855
PRK 40 B - 15	2650/760			250 - 1520	powered						235		905
PRK 40 S - 15	2650/760			500 - 1520	fixed						235		900
PRK 40 B - 16	2500/800			250 - 1600	powered						275		930
PRK 40 S - 16	2500/800			600 - 1600	fixed						275		925
PRK 40 B - 18	2100/915			350 - 1830	powered						295		970
PRK 40 S - 18	2100/915			630 - 1830	fixed						295		965
PRK 40 - Long arm split													
PRK 40 TB - 13	3000/650	1150	III/IV	250 - 1300	powered	1040	250x400	200	195/200	215	205	333	815
PRK 40 TS - 13	3000/650			500 - 1300	fixed						205		810
PRK 40 TB - 14	2800/725			250 - 1450	powered						220		850
PRK 40 TS - 14	2800/725			500 - 1450	fixed						220		845
PRK 40 TB - 15	2650/760			250 - 1520	powered						230		895
PRK 40 TS - 15	2650/760			500 - 1520	fixed						230		890
PRK 40 TB - 16	2500/800			250 - 1600	powered						270		920
PRK 40 TS - 16	2500/800			600 - 1600	fixed						270		915
PRK 40 TB - 18	2100/915			350 - 1830	powered						290		960
PRK 40 TS - 18	2100/915			630 - 1830	fixed						290		955

- 2 hydraulic functions required
- includes hoses and couplings
- optional surfaces see page 72
- other surfaces upon request
- centre cover upon request

- 160 bar pressure at entry required, less pressure results in less clamping force
- powered short arm sequential movement as standard, positioning at 45°, choose on order (no add-on price)
- 0° arm design upon request

- one piece contact plate per arm upon request
- load extender upon request
- quick release hooks ISO III/ISO IV upon request
- force options see page 249



image shows unit complete with optional centre cover