

Multiple fork positioner for 4-6 pallets

SPK-2

The **multiple fork positioner SPK** is ideal for picking up and transporting 4 or 6 pallets at one time. Despite the stable and robust construction it offers excellent visibility to the operator. The outer forks spread beyond the attachment frame width.

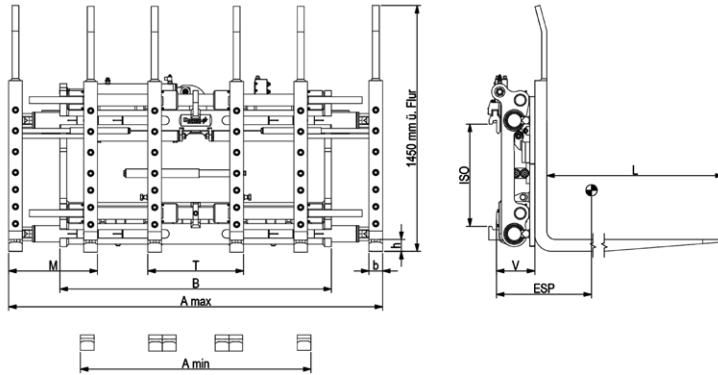

type	lift truck to LC mm	min. carriage mm	capacity kg LC mm	ISO	B mm	opening range A AK-AK mm	M/N/O mm	forks b x h x L mm	sideshift mm	V LLC mm	COG/ESP hor. mm	COG/ESP vert. mm	weight kg
SPK 60-2	6,0/600	1650	3000/1200	IV	1860	1340-2290	500/530	80x60x2400	+/- 160	162	520	185	1450
SPK 80-2*	8,0/600	1750	4000/1200		1860	1340-2290	500/520	120x70x2400 80x70x2400		162	560	155	1660
SPK 100-2*	8,0/900	1750 1900	6000/1200		1860 2260	1340-2290 1340-2700	500/520	120x70x2400 80x70x2400		174	550 535	165 176	1880 1945

- 2 hydraulic functions required
- includes hoses and couplings
- constant sideshift as standard

- automatic lubrication system upon request

* also fork section 100x70 / 80x70 mm possible, please ask

